

Stanisław KONOPKA\*, Ewelina KOLANKOWSKA\*

## METHODOLOGICAL ASPECTS OF DETERMINING THE COEFFICIENT OF KINETIC FRICTION OF WHEAT KERNELS ON AN INCLINED PLANE

### METODYCZNE ASPEKTY WYZNACZANIA KINETYCZNEGO WSPÓLCZYNNIKA TARCIA ZIARNIAKÓW PSZENICY METODĄ RÓWNI POCHYLEJ

**Key words:**

coefficient of kinetic friction of seeds, inclined plane, mechatronic measuring device.

**Abstract**

One of the most popular methods of determining the coefficient of kinetic friction between a pair of solid objects involves an inclined plane. However, manual measurements of the time taken by a particle to travel a certain distance (usually performed with a stopwatch) and the angle of an inclined plane (on a scale) are not always highly accurate or precise. The coefficient of kinetic friction has to be determined on the assumption that a particle moves in uniformly accelerated motion. The aim of this study was to analyse particles moving in uniformly accelerated motion on an inclined plane and to modify the method of measuring movement parameters. A mechatronic measuring device and a high-speed camera were used to monitor the movement of wheat kernels on a steel friction plate. The experimental variables were the distance between photosensors (length of the measured section) and the kernel's position relative to the direction of movement. An analysis of the mean values of time taken by particles to travel different distances revealed that the particles were not moving in uniformly accelerated motion. The results indicate that the coefficient of kinetic friction of irregularly shaped particles cannot be determined reliably on an inclined plane. Several recommendations for modifying the test stand were proposed.

**Słowa kluczowe:**

kinetyczny współczynnik tarcia nasion, metoda równi pochyłej, mechatroniczne urządzenie pomiarowe.

**Streszczenie**

Jednym z bardziej popularnych sposobów wyznaczania tzw. kinetycznego współczynnika tarcia zewnętrznej między parą ciał stałych jest metoda równi pochyłej. Niestety, manualny pomiar czasu ruchu cząstki (zazwyczaj za pomocą stopera) oraz wzrokowy odczyt (na skali) wartości kąta mają bezpośredni związek z dokładnością i precyzją pomiarów. Dodatkowym, koniecznym do spełnienia warunkiem, by możliwe było wyznaczanie wartości kinetycznego współczynnika tarcia jest założenie, że cząstka porusza się po podłożu ruchem jednostajnie przyspieszonym. Celem pracy była weryfikacja warunku poruszania się cząstek ruchem jednostajnie przyspieszonym po podłożu zamocowanym do równi oraz modyfikacja techniki pomiaru parametrów ruchu. Do badań wykorzystano mechatroniczne urządzenie pomiarowe oraz kamerę do szybkich zdjęć, umożliwiającą monitorowanie ruchu cząstek (ziarniaków pszenicy po podłożu ze stali). Zmieniano: odległość między fotokomórkami (długość odcinka pomiarowego) oraz wariant ułożenia ziarniaka w stosunku do kierunku ruchu. Analiza średnich wartości czasu przebycia określonych odcinków pomiarowych (dla poszczególnych ułożeń ziarniaków) wykazała, że nie mają one znamion charakterystycznych dla ruchu jednostajnie przyspieszonego. Stwierdzono, że wyznaczanie kinetycznego współczynnika tarcia metodą równi pochyłej dla cząstek o nieregularnym kształcie jest mało wiarygodne. Zaproponowano wskazówki dotyczące modernizacji stanowiska pomiarowego

## INTRODUCTION

According to the existing body of knowledge on external friction, the phenomena associated with resistance to motion are determined by numerous factors and cannot be described with a single general theory. External

friction differs in fluids and between the contacting surfaces of two objects in relative motion. A wide variety of theories, methods, and measuring techniques have been proposed for monitoring biomass properties such as caking, bridging, ratholing, and tunnelling [L. 1–9]. However, due to the wide variety of measuring

\* University of Warmia and Mazury in Olsztyn, ul. Michała Oczapowskiego 11, 10-719 Olsztyn, Poland.

methods, examined materials and measuring conditions, the relevant analyses often produce discrepant results [L. 2, 10–13]. Therefore, the studies of physical properties of granular materials, including seed mixtures, are permanent [L. 14–18].

One of the most popular methods of determining the coefficient of kinetic friction between a pair of solid objects involves an inclined plane [L. 19, 20]. The inclined plate method is widely used in modelling the processes associated with harvesting, transporting, storage, separation, and sorting of agricultural crops. The values of the coefficient of kinetic friction often determine the effectiveness of successive operations or even entire production processes. They influence the efficiency, effectiveness, and energy consumption of production processes and the quality of products [L. 21].

However, manual measurements of the time taken by a particle to travel a certain distance (usually performed with a stopwatch) and the angle of an inclined plane (on a scale) are not always highly accurate or precise. The coefficient of kinetic friction should be determined on the assumption that a particle moves in uniformly accelerated motion [L. 20].

The aim of this study was to verify the requirements for the uniformly accelerated motion of particles on an inclined plane, and to modify the method of measuring movement parameters.

## EXPERIMENTAL DETAILS

The experiment was performed on kernels of spring wheat cv. Tybalt purchased in the Olsztyn Potato and Seed Plant (OLZNAS-CN Ltd.). One hundred kernels were randomly selected for the study.

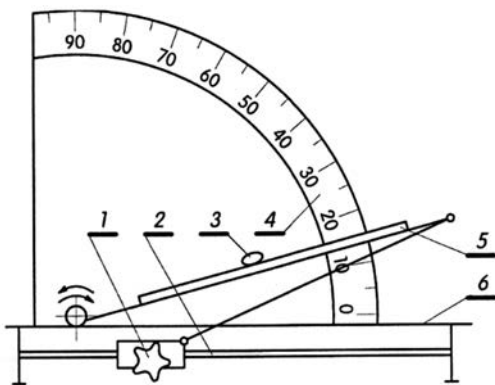

**Fig. 1. Diagram of an inclined plane with an adjustable arm [L. 19]: 1 – screw for adjusting the inclination angle of the arm (plane), 2 – guide, 3 – examined particle, 4 – protractor, 5 – friction plate, 6 – base**

Rys. 1. Schemat równi o zmiennym kącie pochylecia ramienia [L. 19]: 1 – pokrętko regulacji kąta nachylecia ramienia (równi), 2 – prowadnica, 3 – badana cząstka, 4 – kątomierz, 5 – płytką badanego materiału (podłożę), 6 – podstawa

The coefficient of kinetic friction ( $f_k$ ) is measured on an inclined plane (Fig. 1) by placing a particle of bulk material (a wheat kernel) on a friction plate that is attached to a moving arm (5) set at angle ( $\beta$ ) that is greater than the angle of static equilibrium ( $\varphi$ ).

The tangent of angle ( $\varphi$ ) determines the coefficient of static friction. In this method of measurement, the time ( $T$ ) taken by a particle (sample) to travel distance ( $D$ ) (length of the arm) is to be determined. The value of the coefficient of kinetic friction ( $f_k$ ) is calculated with Formula (1) [L. 20]:

$$f_k = \operatorname{tg} \varphi - \frac{2D}{gT^2 \cos \beta} \quad (1)$$

where

$D$  – distance travelled by a particle,

$g$  – standard gravity,

$T$  – time taken by a particle to travel the measured distance,

$\varphi$  – angle of static equilibrium,

$\beta$  – angle of the arm during the determination of the coefficient of kinetic friction.

The experiment was performed with the use of measuring equipment at the Department of Heavy Duty Machines and Research Methodology, Faculty of Technical Sciences of the University of Warmia and Mazury in Olsztyn.

The inclined plane was equipped with a mechanical system for lifting the arm and two optoelectronic systems composed of a laser beam emitter and a receiver (photosensor). The top optoelectronic system was mounted in a fixed position, whereas the other system was mounted in openings drilled at various points in the side bars of the arm to change the distance ( $D_i$ ) travelled by a particle. Both optoelectronic systems were connected to a computer via a CPU controller, and data were registered online. The arm's angle of inclination ( $\varphi$ ) relative to the horizontal plane (the moment when the laser beam of the top optoelectronic system is interrupted marks the beginning of particle movement) and the time ( $T_i$ ) taken by a particle to travel a given distance between the top and bottom sensor were registered. Angle ( $\varphi$ ) was measured to the nearest  $0.01^\circ$ , and time was measured to the nearest millisecond (ms).

The i-SPEED TR high-speed camera was used to determine whether a particle moves in a uniformly accelerated motion (Fig. 2).

The experiment was carried out based on the following assumptions:

- The relative moisture content of wheat kernels was kept constant at 12.7% during the measurements.
- Kernels move in uniformly accelerated motion from the moment their movement is initiated (the laser beam of the top optoelectronic system is interrupted).
- The results of measurements are not influenced by environmental conditions (light, temperature, absolute humidity).

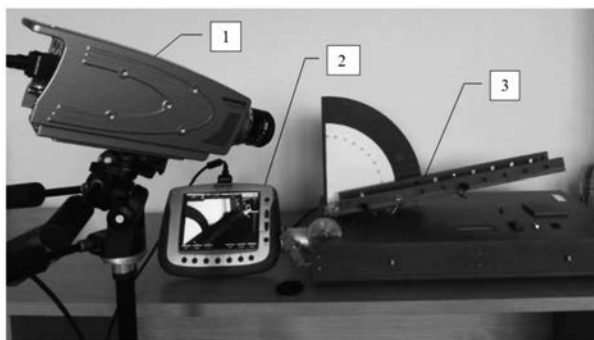

**Fig. 2.** Test stand with a high-speed camera for registering the movement of particles on an inclined plane [L. 22]: 1 – high-speed camera, 2 – display, 3 – inclined plane

Rys. 2. Widok stanowiska pomiarowego z umieszczoną obok kamerą do szybkich zdjęć do monitorowania ruchu cząstek po podłożu zamocowanym do ramienia (równi) [L. 22]: 1 – kamera do szybkich zdjęć, 2 – wyświetlacz zewnętrzny, 3 – równia

The experimental constants were as follows:

- The angular velocity of the arm, set at 0.087 rad s<sup>-1</sup> as the maximum value (previous experiments demonstrated that this parameter does not affect the beginning of a particle's movement on an inclined plane) [L. 21]; and,
- The type of structural material (friction plate) on which particles move – INOX 1.4301 stainless steel with roughness average Ra = 0.21 μm determined with a Hommel T1000 surface roughness tester.
- The experimental variables were as follows:
- Distance between photosensors ( $D_i$ ): 140, 240, 340, 440 mm; and,

- The position of kernels relative to the direction of movement ( $U_i$ ) – (Fig. 3).

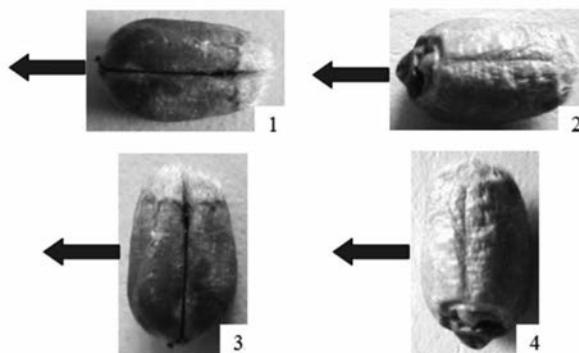

**Fig. 3.** Position of a kernel's longitudinal axis relative to the direction of movement [L. 22]: 1 – parallel, with the crease up, 2 – parallel, with the crease down, 3 – perpendicular, with the crease up, 4 – perpendicular, with the crease down

Rys. 3. Ułożenie ziarniaków pszenicy względem kierunku ich ruchu [L. 22]: 1 – podłużnie, bruzdką do góry, 2 – podłużnie bruzdką do dołu, 3 – poprzecznie, bruzdką do góry, 4 – poprzecznie, bruzdką do dołu

Wheat kernels were placed on the inclined plane with the use of tweezers, directly above the laser beam of the top optoelectronic system (Fig. 4). The lifting mechanism was activated, and the measurements were performed until the laser beam of the bottom optoelectronic system was interrupted. The following parameters were registered: initial angle ( $\varphi_i$ ) and the time ( $T_i$ ) taken by the kernel to travel a given distance ( $D_i$ ). The measured data were transmitted to the computer.

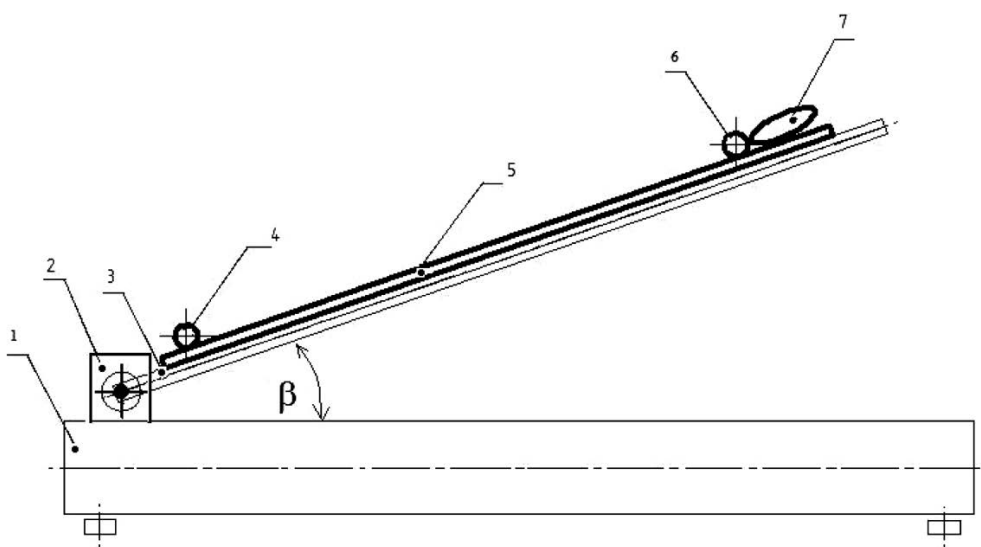

**Fig. 4.** Measurement technique [L. 23]: 1 – base of the test stand, 2 – arm lifting mechanism, 3 – arm (inclined plane), 4 – bottom optoelectronic system, 5 – friction plate (steel), 6 – top optoelectronic system, 7 – wheat kernel

Rys. 4. Schemat ilustrujący technikę wykonywania pomiarów [L. 23]: 1 – podstawa stanowiska badawczego, 2 – układ unoszenia ramienia, 3 – ramię (równia), 4 – dolny układ optoelektroniczny, 5 – podłoże (stalowa płytka), 6 – górny układ optoelektroniczny, 7 – ziarniak pszenicy

The movement of every kernel on the inclined plane was recorded with a high-speed camera.

The results of the measurements were processed statistically to achieve the following [L. 24]:

- Determine basic statistical parameters (mean values and standard deviation) for the measured parameter (time of travel) for given kernel position ( $U_i$ ) and distance ( $D_i$ );
- Verify whether the size of the initial sample ( $n_0 = 100$ ) has sufficient statistical power;
- Compare the distribution of data (for every combination of variables) with normal distribution (Shapiro-Wilk test) and assess the equality of variances of the compared parameters (Levene's test); and,
- Conduct parametric or non-parametric tests, subject to the results of the verification procedure, to compare the average time of travel for every kernel position ( $U_i$ ) and every analysed distance ( $D_i$ ).

All calculations were performed in the Statistica v. 13.1 program at a significance level of  $\alpha = 0.05$ .

## RESULTS AND DISCUSSION

The null hypothesis stating that the measured parameters, i.e. time ( $T_i$ ) of traveling a specified distance ( $D_i$ ), are

characterized by normal distribution and homogeneity of variance could not be rejected for the tested kernel positions ( $U_i$ ) and distances ( $D_i$ ). In further analyses, the significance of differences between the mean values of time ( $T_i$ ) for different distances ( $D_i$ ) and different kernel positions ( $U_i$ ) were determined by analysis of variance (ANOVA). Significant differences were analysed by Duncan's multiple range test to determine homogeneous groups.

The results of calculations (Table 1) revealed that the size of the initial sample (100 kernels) had sufficient statistical power. The minimum size of the sample was below the anticipated value.

Significant differences in mean time of travel were observed in all combinations of variables. When wheat kernels were placed on the steel plate in position  $U_1$  (with the dorsal side down and the longitudinal axis parallel to the direction of movement), a homogeneous group was determined for distances ( $D_i$ ) 140 and 240 mm. These findings imply that kernels did not travel the above distances in uniformly accelerated motion.

Homogeneous groups for the mean time ( $T_i$ ) taken by the kernel to travel distance ( $D_i$ ) were not determined for the remaining kernel positions. However, a detailed analysis revealed that the distributions of mean time values ( $T_i$ ) (with a line denoting the observed changes) are not indicative of uniformly accelerated motion (distance

**Table 1. Statistical parameters and the results of the analysis of variance comparing the mean values of time ( $T_i$ ) for different distances ( $D_i$ ) and different positions of wheat kernels ( $U_i$ ) relative to the direction of movement**

Tabela 1. Zestawienie statystycznych parametrów oraz wyników analizy wariancji dotyczącej porównań średnich wartości czasu ( $T_i$ ) dla różnych długości odcinka pomiarowego ( $D_i$ ), przy danym sposobie układania ( $U_i$ ) ziarniaków pszenicy w stosunku do kierunku ich ruchu

Distance $D_i$ (mm)	Minimum sample size	Mean time $T_i$ (s)*	Standard deviation for variable $T_i$ (s)	F-distribution	Probability value
Kernel position $U_1$					
140	69	0.38 <sup>a</sup>	0.113	97.38	0.000
240	73	0.42 <sup>a</sup>	0.156		
340	59	0.48 <sup>b</sup>	0.094		
440	65	0.71 <sup>c</sup>	0.202		
Kernel position $U_2$					
140	62	0.43 <sup>a</sup>	0.081	125.74	0.000
240	71	0.54 <sup>b</sup>	0.163		
340	72	0.74 <sup>c</sup>	0.186		
440	85	0.89 <sup>d</sup>	0.256		
Kernel position $U_3$					
140	68	0.34 <sup>a</sup>	0.119	124.27	0.000
240	83	0.54 <sup>b</sup>	0.201		
340	87	0.63 <sup>c</sup>	0.234		
440	85	0.88 <sup>d</sup>	0.237		
Kernel position $U_4$					
140	89	0.58 <sup>a</sup>	0.233	57.24	0.000
240	91	0.69 <sup>b</sup>	0.274		
340	90	0.87 <sup>c</sup>	0.251		
440	95	1.06 <sup>d</sup>	0.344		

\* – mean values denoted by the same letters (for different kernel positions  $U_i$ ) do not differ significantly (homogeneous groups).

$D_i$  travelled by a kernel over time should resemble the arm of a parabola). The above can be clearly observed in **Figure 5**, which is a time-distance diagram for kernels in position  $U_3$  (dorsal side down, with the longitudinal axis perpendicular to the direction of movement).

The most rapid increase in mean time ( $T_i$ ) was observed for distances  $D_3 = 340$  and  $D_4 = 440$  mm. The above increase was estimated at 48%, and it was noted for kernel position  $U_1$  (dorsal side down, with longitudinal axis parallel to the direction of movement). The difference between the mean time of travel across distances ( $D_3$ ) and ( $D_4$ ) was 0.23 s. The above result cannot be directly explained. According to the literature [L. 25], the initial movement of an object (kernel) is chaotic in measurements of this type, and it is stabilized after a certain time, i.e. after the kernel has travelled a certain distance. However, the length of the “stabilizing” distance has not been specified.

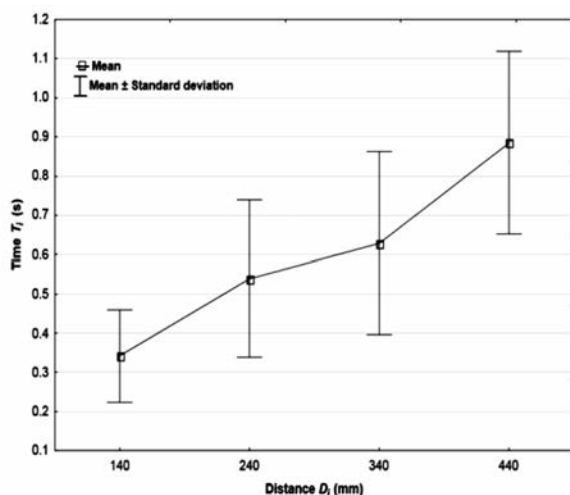

**Fig. 5. Variations in the mean values of time ( $T_i$ ) registered for various distances between photosensors and kernel position  $U_3$**

Rys. 5. Ilustracja zmienności średnich wartości czasu ( $T_i$ ) zarejestrowanych dla różnych odległości między fotokomórkami przy ułożeniu nasion ( $U_3$ )

The results of statistical analyses were confirmed by the images taken with a high-speed camera. Still frames were used to identify the phenomena occurring during the measurements. A visualization of the trajectory travelled by a kernel in position ( $U_3$ ) revealed that the kernel rotates around its longitudinal axis at the beginning of movement. In successive stages of motion, the kernel bounces off the friction plate and the side bars of the inclined plane, which disrupts the stability of motion (**Fig. 6**).



**Fig. 6. Visualization of the trajectory traveled by a kernel on an inclined plate during measurements of movement parameters**

Rys. 6. Przykładowa wizualizacja ruchu ziarniaka pszenicy w trakcie pomiaru parametrów ruchu cząstki po podłożu zamocowanym do ramienia równi

## CONCLUSIONS

1. The results of the experiment and statistical analyses revealed that the coefficient of kinetic friction of irregularly shaped particles, such as wheat kernels, cannot be reliably determined on an inclined plane. Irregularly sized particles move in an unstable manner, which generates measurement errors. Differences in the particles position (relative to the direction of movement) did not induce uniformly accelerated motion, which is the key prerequisite for determining the coefficient of kinetic friction.
2. In this study, the use of a mechatronic measuring device and a fast-speed camera for monitoring the phenomena occurring during the experiment improved the accuracy with which the observed parameters were registered and analysed.
3. The results of this study can also be used to formulate the following practical recommendations for test stand design:
  - The length of the inclined plane (distance travelled by the particle) should be increased and optimization.
  - A neutral section in the first phase of particle movement (around 0.5 m) should be eliminated from measurements to stabilize the movement.
  - The width of the arm should be increased to prevent particles from bouncing off the side bars.

## REFERENCES

1. Lawton P.J.: Coefficients of friction between cereal grain and various silo wall materials. J. Agric. Eng. Res., 1980, 25(1), pp. 75–86.

2. Nosal S.: Tribologia. Wprowadzenie do zagadnień tarcia, zużywania i smarowania. Publishing House of the Poznan University of Technology. 2012.
3. Chevanan N., Womac A.R., Bitra V.S.P., Yoder D.C., Sokhansanj S.: Flowability parameters for chopped switchgrass, wheat straw and corn stover. *Powder Technol.* 2009, 193, pp. 79–86, <http://dx.doi.org/10.1016/j.powtec.2009.02.009>.
4. Fitzpatrick J.J., Barry K., Cerqueira P.S.M., Iqbal T., O'Neill, J., Ross Y.H.: Effect of composition and storage conditions on the flowability of dairy powders. *Int. Dairy J.* 2007, 17(4), pp. 383–392, <http://dx.doi.org/10.1016/j.idairyj.2006.04.010>.
5. Ganesan V., Muthukumarappan K., Rosentrater K.A.: Flow properties of DDGS with varying soluble and moisture contents using jenike shear testing. *Powder Technol.* 2008, 187(2), pp. 130–137, <http://dx.doi.org/10.1016/j.powtec.2008.02.003>.
6. Landillon V., Cassan D., Morel M.-H., Cuq B.: Flowability, cohesive, and granulation properties of wheat powders; *J. Food Eng.* 2008, 86(2), pp. 178–193, <https://dx.doi.org/10.1016/j.jfoodeng.2007.09.022>.
7. Mattsson J.E., Kofman P.D.: Method and apparatus for measuring the tendency of solid biofuels to bridge over openings. *Biomass and Bioenerg.* 2002, 22(3), pp. 179–185, [https://dx.doi.org/10.1016/S0961-9534\(01\)00067-8](https://dx.doi.org/10.1016/S0961-9534(01)00067-8).
8. Schwedes J., Review on testers for measuring flow properties of bulk solids. *Granular Matter* 2003, 5, pp. 1–43, <https://dx.doi.org/10.1007/s10035-002-0124-4>.
9. Zou Y., Brusewitz G.H.: Flowability of uncompacted marigold powder as affected by moisture content. *J. Food Eng.* 2002, 55(2), pp. 165–171, [https://dx.doi.org/10.1016/S0260-8774\(02\)00060-2](https://dx.doi.org/10.1016/S0260-8774(02)00060-2).
10. Borys P.: Skąd się bierze tarcie? Publishing House of the Silesian University of Technology, FOTON 106. 2009.
11. Lawrowski Z.: Tribologia. Tarcie, zużywanie i smarowanie; Publisher: Oficyna Wydawnicza Politechniki Wrocławskiej 2008 (in Polish).
12. Przywara M., Oliwa J., Opaliński I.: Wpływ wilgotności na charakterystyki płynięcia alternatywnych biopaliw stałych. Cz. 1. Biomasa leśna i AGRO, Inż. Ap. Chem. 2013; 52, 6, pp. 554–556 (in Polish).
13. Vilde A., Sevostjanovs G., Nowak J.: Theories of friction and their applicability to soil. *TEKA Kom. Mot. Energ. Roln. – OL PAN*, 2007, 7, pp. 250–260.
14. Horabik J., Molenda M.: Właściwości fizyczne sypkich surowców spożywczych. Zarys katalogu; *Acta Agrophysica*; Lublin, 74, Publisher: Bohdan Dobrzański Institute of Agrophysics Polish Academy of Sciences, 2002 (in Polish).
15. Izli N., Unal H., Sincik M.: Physical and mechanical properties of rapeseed at different moisture content. *International Agrophysics*, 2009, 23, pp. 137–145.
16. Kara M., Bastaban S., Öztürk I., Kalkan F., Yildiz C.: Moisture-dependent frictional and aerodynamic properties of safflower seeds. *International Agrophysics*, 2012, 26, pp. 203–205.
17. Kibar H., Öztürk T.: Physical and mechanical properties of soybean. *International Agrophysics*, 2008, 22, pp. 239–244.
18. Taheri-Garavand A., Nassiri A., Gharibzahedi S.M.T.: Physical and mechanical properties of hemp seed. *International Agrophysics*, 2012, 26, pp. 211–215.
19. Kaliniewicz Z., Rawa T.: Laboratorium z maszyn rolniczych; Publisher: Wydawnictwo Uniwersytetu Warmińsko-Mazurskiego w Olsztynie 2000 (in Polish).
20. Konopka S.: Analiza procesu separacji nasion gryki przy wykorzystaniu prętowych powierzchni roboczych; *Inżynieria Rolnicza* 2006, 8(83) (in Polish).
21. Bakier S., Konopka S., Lipiński A., Anders A., Obidziński S., Bareja K., Bajko E.: Mechaniczne metody wyznaczania współczynników tarcia statycznego pojedynczych cząstek roślinnych materiałów sypkich. *Innowacyjne metody w badaniach agrofizycznych*, Publisher: Wyd. Naukowe FRNA, Lublin 2015, pp. 29–66, ISBN 9788360489284 (in Polish).
22. Bareja K.: Badanie współczynników tarcia zewnętrznego wybranych nasion przy wykorzystaniu urządzenia z mechatronicznym układem pomiarowym; Praca doktorska, Wydział Nauk Technicznych, Uniwersytet Warmińsko Mazurski w Olsztynie, 19.03. 2015 r. (in Polish).
23. Gizińska-Urbańska R., Konopka S.: Comparison of external friction coefficients for single seeds in the stabilised system. *Agr. Eng.*, 2014, 2(150), pp. 201–208, <http://dx.medra.org/10.14654/ir.2014.150.046>.
24. Rabiej M.: Statystyka z programem Statistica [Statistics in Statistica software]; Publisher: Helion, Gliwice, 2012, pp. 1–344 (in Polish).
25. Horabik J.: Charakterystyka właściwości fizycznych roślinnych materiałów sypkich istotnych w procesach składowania. *Acta Agrophysica*; Lublin, 2001, 54, Publisher: Bohdan Dobrzański Institute of Agrophysics Polish Academy of Sciences, 2001 (in Polish).